



WICHITA STATE
UNIVERSITY

UNIVERSITY LIBRARIES

Repeatability and reproducibility studies: a comparison of techniques

Item Type	Thesis
Authors	Pandiripalli, Bhavani
Publisher	Wichita State University
Rights	Copyright Bhavani Pandiripalli, 2010. All rights reserved
Download date	2026-05-20 05:02:11
Link to Item	http://hdl.handle.net/10057/3736

**REPEATABILITY AND REPRODUCIBILITY STUDIES: A COMPARISON OF
TECHNIQUES**

A Thesis by

Bhavani Pandiripalli

Bachelor of Engineering, Chaitanya Bharathi Institute of Technology, 2007

Submitted to the Department of Industrial and Manufacturing Engineering
and the faculty of the Graduate School of
Wichita State University
in partial fulfillment of
the requirements for the degree of
Master of Science

December 2010

© Copyright 2010 by Bhavani Pandiripalli

All Rights Reserved

REPEATABILITY AND REPRODUCIBILITY STUDIES: A COMPARISON OF TECHNIQUES

The following Faculty members have examined the final copy of this thesis for form and content and recommend that it be accepted in partial fulfillment of the requirement for the degree of Master of Science with a major in Industrial Engineering

Gamal Weheba, Committee Chair

Krishna Krishnan, Committee Member

Ramazan Asmatulu, Committee Member

DEDICATION

To my parents,
Narendar. P & Subashini. P
my brothers
Bhuvan. P & Sriram. P
and my late Grandmother,
Kamala Bai. P

ACKNOWLEDGEMENT

I would like to express my sincere thanks and appreciation to my advisor, Dr. Gamal Weheba for his constant encouragement and support throughout my Master's degree in Wichita State University. I am highly obliged for his guidance and motivation, which helped me achieve success as a graduate student.

I am very thankful to my parents whose support and encouragement made it possible for me to pursue my higher education at Wichita State University. I would like to thank my brothers for their guidance, moral support and motivation throughout my graduate studies.

I would also like to thank all my friends for their love and support to help me make this work a success. Finally, I would like to thank Akale, who has trained me in the data collection and operation of Spectrum Analyzer.

ABSTRACT

Gage Repeatability & Reproducibility (GRR) Studies have become critical in process improvement projects in the manufacturing sectors. There are various methods to conduct GRR study. However, the most widely used is the Automotive Industry Action Group (AIAG) method, which was standardized after the recognition of the importance of measurement systems. In this study, AIAG method and Wheeler's method are compared, with specific interest in the proportions of the estimates of variation.

An experimental study was designed, with factors being the operators and parts. The spectrum analyzer – Quattro, was tested for its adequacy of measurement and to understand the variability in the measurement system. In this research, vibration-impact testing was performed on Stereolithography (SL) parts and the measured feature was the natural frequency. The data was analyzed following the AIAG method and that proposed by Wheeler.

From the results obtained, the Repeatability and Reproducibility were over estimated by AIAG method in comparison to Wheeler's. The Wheeler's method gave a better understanding of the sources of variation. Due to which, the measurement system capability could be judged without bias. Also, Wheeler's method helps in making right decisions about the measurement system. Therefore, Wheeler's method is strongly recommended over the AIAG.

TABLE OF CONTENTS

CHAPTER	PAGE
1. INTRODUCTION.....	1
2. LITERATURE REVIEW.....	3
2.1 Measurement System.....	3
2.2 Concepts of Gage Repeatability & Reproducibility.....	6
2.3 AIAG Standard.....	10
2.4 Wheeler's Method.....	20
2.5 Vibrations.....	22
2.6 Stereolithography.....	28
3. CASE STUDY.....	30
3.1 Spectrum Analyzer- Quattro & Specifications.....	30
3.2 Experimental Design.....	32
3.3 Data Collection.....	32
3.4 Data Analysis.....	34
3.5 Results.....	36
3.6 Comparison of methods.....	38
3.7 Selection of appropriate method.....	39
4. SUMMARY & CONCLUSIONS.....	40
REFERENCES.....	42
APPENDICES.....	46
A. Factors for Constructing Variables Control Charts.....	47
B. Duncan's Table for d_2^* Values.....	48

LIST OF FIGURES

FIGURE	PAGE
2.1. Concepts of Accuracy and Precision.....	4
2.2. Repeatability.....	7
2.3. Reproducibility.....	7
2.4. GRR Data Collection Sheet.....	16
2.5. GRR Report.....	16
2.6. ANOVA Table.....	18
2.7 Four Classes of Process Monitors.....	21
2.8 Characterization of Measurement System Based on Class Monitors.....	21
2.9. Small oscillations of a spring and mass set up.....	22
2.10a. Actual time-domain signature.....	23
2.10b. Theoretical time domain waveform.....	23
2.10c. Typical frequency-domain signature.....	24
2.11. Hammer Details.....	27
2.12. System configuration of vibration-impact testing.....	27
2.13. SLA process.....	29
3.1. Quattro- Spectrum Analyzer used for this study.....	30
3.2 Flow chart showing the research methodology.....	34
3.3 Output Display of Frequency plot.....	34
3.4 X-bar Chart plotted for Natural Frequency.....	35
3.5 Range Chart plotted for Natural Frequency.....	35

LIST OF TABLES

TABLE	PAGE
2.1. Steps followed in AIAG method	13
2.2. Gage R&R Criteria.....	19
2.3 Steps followed in Wheeler's method.....	20
3.1 Quattro Specifications.....	31
3.2 Data collected by operators A and B.....	32
3.3 Calculated Averages and ranges for the data.....	33
3.4. Results from AIAG method.....	36
3.5. Results from Wheeler's method.....	37
3.6. AIAG proportions vs. Wheeler's proportions.....	38

CHAPTER 1

INTRODUCTION

Measurements are the fundamental elements for improvement of a product or a process or any kind of service. Quality being a major concern for any sector, the measurement system impacts the decisions to adjust and control a process. The quality of the data measured is vital for appropriate understanding, monitoring or improving a process. If the data is contaminated with errors, it could lead to wrong decisions. The ability to make right decisions depends on the availability of a measurement process, selecting the right measurement process and operating the measurement process in the correct manner. Most of the quality problems in industries are solved by identifying and correcting inaccurate data and inaccurate measurement process.

Measurement uncertainty is characterized by accuracy and precision. Accuracy is the agreement of measurements with the accepted reference value. Precision is the agreement of individual measurements with each other. Precision is the degree of Repeatability and Reproducibility. Repeatability is the variability attributed by the gage and Reproducibility is the variability attributed by the operators using the gage. Also there are errors due to bias, linearity, stability, sensitivity, discrimination, stability and resolution. These characterize the uncertainty in a measurement system, but Repeatability and Reproducibility are the major contributors. Therefore, Repeatability and Reproducibility quantification is critical for the judgment of adequacy of a measurement system.

In order to reduce the variations in a process, it is necessary to identify the sources of variation, quantify them and to have an understanding about the proper operation of the gage that is being used for collecting the measurements. In operating a gage, measurement

error can be contributed to various sources like within-sample variation, measurement method, the gage/instrument used for measurement, operators, temperature, environment and other factors. Therefore, it is necessary to conduct a study on measurement system capability. This study is termed as Gage Repeatability and Reproducibility (GRR) study or gage capability analysis.

A quality product is a result of an efficient measurement system. The results of the GRR study analysis are used for assessing the capability, performance, control, defect identification and isolation, for the entire manufacturing process. Therefore, quality practitioners felt the importance of GRR study and it was made a part of requirements of QS9000 initiated by the Ford Company. In order to set-up an international standard of measurement for various manufacturers, Measurement System Analysis had been developed accordingly by AIAG.

In this research, a measurement capability analysis is performed on a Dynamic Signal Analyzer or Spectrum Analyzer, which is used for modal testing. The parts selected for the study were constructed by Stereolithography (SL) technique, built at three different orientations i.e., X, Y and Z. These parts were subjected to vibration-impact testing for measuring their natural frequencies. The data was collected, analyzed and compared for the variance components, following AIAG standard and Wheeler's method.

In the following chapter, literature review describes the errors in measurement system, Gage Repeatability and Reproducibility studies, Vibration-impact testing and SL process. In chapter 3, the experimental work, results and comparison of methods are presented. Chapter 4 details the summary and conclusions.

CHAPTER 2

LITERATURE REVIEW

This chapter describes the previous research work carried out in performing GRR study using various methods. Section 2.1 discusses the measurement system and the errors associated with it. Detailed description of the GRR studies and evolution of GRR methods are presented in section 2.2. Section 2.3 discusses the metrics of measurement error, methods of data analysis and interpretation of the results by AIAG (2002) standard. Section 2.4 details Wheeler's method in conducting a GRR study. Section 2.5 discusses theory of vibrations, vibration-impact testing and spectrum analyzer. In section 2.6, the SL process and its advantages are discussed.

2.1 Measurement System

Measurement is defined as “the process of assigning numbers (or values) represent quantities”, by Campbell (1938). A measurement system is the collection of instruments or gages, standards, operations, methods, fixtures, software, personnel, environment and assumptions used to quantify a unit of measure (AIAG, 2002). To improve the quality of a product, in any sector, it relies on the quality of data. The data necessarily is used for controlling and improving a process. The three possible uses of data as stated by Knowles et.al, 2000 are to characterize products, process or item.

The quality of the data depends upon two main factors, accuracy and precision. Accuracy is defined as the ability to measure the true value correctly, whereas, precision is defined as the closeness of the measured readings to each other. From the figure 2.1, the bull's eye of the target is considered to be the true value of the measured characteristic. The measured values are represented by plus sign. In top left figure, the measurements are not

accurate and imprecise. The figure on top right is an indication of precision but inaccurate measurements. The bottom left figure shows measurements which are accurate but imprecise. In bottom right figure, the measurements are both accurate and precise.

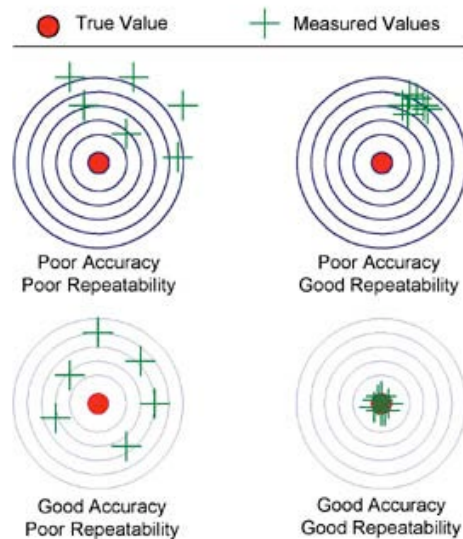

Figure 2.1. Concepts of Accuracy and Precision (Source: Dawson, 2004)

In order to evaluate the accuracy of a gage or a measurement system, a standard is required, for which the true value of the measured characteristic is known. Precision is a measure of the inherent variability in the measurements. Precision gives information about the quality of the gage. According to Montgomery (2001), accuracy can be determined with a single measurement unlike precision that requires repeated measurements.

2.1.1 Errors in a Measurement System

In a group of collected measurements using a gage, there are variations attributed to the actual process or the measurement system or both. The measurement system can be characterized based on its location and spread (variance) as defined in AIAG, 2002. Location error can be categorized by accuracy, bias, stability and linearity. The spread error can be categorized as precision, repeatability, and reproducibility. Bias is the difference between the average observed value and the reference value of the same characteristic on the same part.

The major causes of excessive bias are poor calibration or worn gage, wrong gage for application, different measurement methods, parallax and environment. Stability is the variation obtained by the measurement system by measuring the same characteristic, on the same part over a period of time or it is change in bias over time. Linearity is the change in bias with respect to size attributes to linearity.

The purpose of GRR study as stated by Burdick.R, Borrer.C and Montgomery.D (2005) is to determine the amount of variability in the collected data that is due to the measurement system, isolate the sources of variability in the measurement system, assess whether the measurement system is suitable for broader application, and quantify the variability in the measurement process attributed by the operators, parts and operators-part interaction.

2.1.2 Ratios in Measurement System

Precision to Tolerance (P/T)

According to Maass (2001), the precision to tolerance ratio is the ratio between estimated measurement error and the tolerance of the characteristic being measured and equation 2.3 is given by,

$$P/T = \frac{6\sigma_{\text{measurement}}}{USL - LSL} \quad (2.1)$$

Precision to Total Variation (P/TV)

This is the ratio between measurement variation and the total variation, which is the sum of product variation and measurement variation (AIAG, 1995). Equation 2.4 is given as,

$$P/TV = \frac{\text{MeasurementVariation}}{\text{ProductVariation} + \text{MeasurementVariation}} \quad (2.2)$$

If the measurement variation is large, the measurement process cannot be monitored, therefore, resulting in inadequacy of the measurement system.

If the measurement variation is large, the measurement process cannot be monitored and hence the measurement system is inadequate.

2.2 Concepts of Gage Repeatability & Reproducibility Study

In Statistical Process Control (SPC) program, the goal is continuous improvement through reduction of variability in a process. For this, SPC depends on the measurement and test data as primary inputs for the assessment of process improvement. To address actual process variability, the variation due to the measurement system must be identified and separated from that of the process variability (Barrentine, 1991). Therefore, a GRR study is carried out in order to address and provide quantitative information about the performance of a measurement process.

In a measurement system as stated by Barrentine.L (1991) the possible sources of variation are the gage (repeatability), the operator (reproducibility) and the variation within the sample (part-to-part variation). Repeatability and Reproducibility together are the components of “measurement error”. GRR study quantifies the variation relative to the total variation in terms of percentage of total variation and relative to specification range or percentage of tolerance.

The performance of a gage can be evaluated by finding the variation in measurements generated with it. The ratio of total measurement variation to part tolerance range is used as an index to indicate whether the gauge is in good condition for continued use (Tsai, 1988).

2.2.1 Repeatability and Reproducibility

The variation observed in measurements, when one operator repeatedly measures the same feature(s) on the same part(s) and in same place(s). This is addressed as gage repeatability. Figure 2.2 depicts the probability density function constructed from repeated measurements.

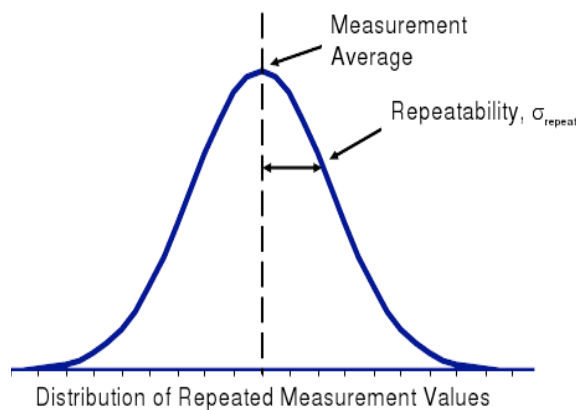

Figure 2.2. Repeatability (Source: www.raytheon.com)

Whereas, the variation observed in measurements when different operators measure the same feature(s) on the same or different parts in the same place(s). This is addressed as Reproducibility or operator variation.

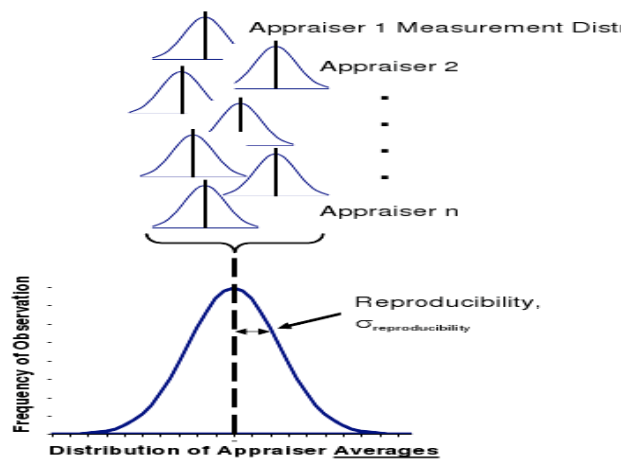

Figure 2.3. Reproducibility (Source: www.raytheon.com)

Mathematically, Reproducibility is the variability due to average measurements obtained by each operator. Figure 2.3 depicts the probability density functions of different operators.

Though the variabilities are same for individual operators due to the difference in the bias of each operator, the total variability of the measurement system is inflated.

The total variability in a measurement system is attributed to the variability of the product and variability of the gage. And in turn the variability in a gage can be attributed to Repeatability and Reproducibility. The statistical property that is commonly used to characterize the quality of data is bias and variance. Mathematically they are expressed as in equations 2.3 and 2.4 (AIAG, 2002).

$$\sigma_{\text{total}}^2 = \sigma_{\text{product}}^2 + \sigma_{\text{gage}}^2 \quad (2.3)$$

$$\sigma_{\text{gage}}^2 = \sigma_{\text{repeatability}}^2 + \sigma_{\text{reproducibility}}^2 \quad (2.4)$$

The objective of GRR study is to determine whether a measurement procedure or instrument is adequate for monitoring a process, which is relative to the precision of the gage. If the measurement error is small relative to the total variation, then the measurement procedure is deemed as adequate. Similarly, if the total variation is small, it implies that the process is stable (Vardeman & Valkenburg, 1999). By not considering calibration, linearity and stability, does not necessarily mean that they are unimportant, but they are less significant in their impact (Mawby, 2006).

In a GRR study, the number of parts selected should belong to the same process or machine. The number of trials to be performed by each operator has to be at least two, which provides an estimate of gage error. The more is the number of operators, parts and trials; greater is the confidence in the analysis. However, these large numbers involve high costs and more time. Hence, tradeoff decisions have to be made in planning the experiment.

Some studies are carried out by selecting fewer parts with more measurements and others involve few measurements on more number of parts. The latter case has advantages over the other, since a gauge might provide less variable results on a standard unit that is near the center of the manufacturing specifications than on a product at the extremes of the specifications (Montgomery & Runger-I, 1993). Also, the variance of the measurements might not be constant. This will not be detected if a narrow range of parts is selected for the study. With a new part there is always an opportunity to detect new sources of variation.

2.2.2 Evolution of methods

Based on the research, it is evident that there has been a series of modifications in the method followed to conduct a GRR study. According to the research conducted by Knowles et.al, 2000, a traditional or a classical gauge R&R study compares the measurement variation with the engineering specification that is set against the product being measured. This gives the information of the spread of total specification that is consumed by the measurement variation. The limitation of this method is that it does not utilize any graphical representation of data, which prevents into details of variation.

In a modified GRR study, a modification of using total variance instead of total spread was made. This method is a slight modification of traditional GRR study, which follows same limitations of traditional method and also it uses standard deviation for the estimation of sources of variation.

A GRR study was further modified and enhanced as a design of experiment problem (ANOVA method). This method thoroughly addresses and quantifies the sources of variation present in a measurement system. The limitation of this technique is that it states the statistical insignificance of the factors and a measurement process can still be capable.

Therefore, it fails to address the overall capability and the next step to be carried out in order make improvements in the measurement system.

Evaluating the measurement process (EMP) technique is the graphical display of average-range, bias and inconsistency controls charts. It is based on measurement process stability, predictability, centering and spread. The limitation of this method is that, the researchers neglected the operator variation as it was found to be insignificant, where as this issue is addressed by other methods. Also, a modified EMP method was developed which addressed the operator variation.

2.3 AIAG standard (AIAG, 2002)

According to AIAG, 2002 the metrics of measurement error, methods of data analysis, steps followed in conducting the GRR study and the decision criteria for the sources of variation are explained in this section.

2.3.1 Metrics for AIAG method

In Gage R&R study, one of many ways for the assessment of measurement system is by calculating the ratios of measurement variation and part tolerance from the collected data. If the measurement variation is reduced, the ratios differentiate between the parts that are out of specification, and increase the confidence of accepting or rejecting the parts. Therefore, the metrics used are as follows:

Equipment Variation (EV)

The variation caused by equipment during replication of the measurements, is equipment variation. This is an estimate of repeatability attributed by the gage or equipment as given in equation 2.5.

$$EV = \bar{R} * k_1 \quad (2.5)$$

Where,

\bar{R} - Average Range

$k_1=1/d_2$ – values from Factors for Constructing Variables Control Charts (Appendix A)

Appraiser Variation (AV)

This is the variation caused by the difference in the measurement by operators. This is an estimate or reproducibility attributed by operators as given in equation 2.6.

$$AV = \sqrt{[(\bar{X}_{max.} - \bar{X}_{min.}) / d_2]^2 - (EV / nr)^2} \quad (2.6)$$

Where,

n - number of measurements

r - number of trials

Product Variation

The variation within a sample gives rise to product variation. This is attributed by variations in the process of manufacturing of the parts and calculated as given in equation 2.7.

$$PV = R_p * d_2^* \quad (2.7)$$

Where,

R_p - Range of part averages

d_2^* are the values associated with the distribution of the Average Range

Combined Gage R&R

The variation due to combined effect of Repeatability and Reproducibility as given in equation 2.8.

$$GRR = \sqrt{EV^2 + AV^2} . \quad (2.8)$$

Total Variation

It is an estimate obtained by combining Product Variation with the Repeatability & Reproducibility as given in equation 2.9.

$$TV = \sqrt{EV^2 + AV^2 + PV^2} \quad (2.9)$$

After calculating the parameters or the estimates, the percentages of the estimates are calculated for the further analysis of data as in equations 2.10, 2.11, 2.12 and 2.13

$$\%EV = 100 [EV/TV] \quad (2.10)$$

$$\%AV = 100 [AV/TV] \quad (2.11)$$

$$\%GRR = 100 [GRR/TV] \quad (2.12)$$

$$\%PV = 100 [PV/TV] \quad (2.13)$$

The AIAG standardized the method to be followed in order to perform a GRR Study. It is an 11-step methodology, which is summarized in the Table 2.2 below. The formulae for the calculation of estimates of variation and their proportions are listed.

STEPS	FORMULAE
Step 1	$URL = D_4 \bar{R}$
Step 2	$EV = \hat{\sigma}_{pe} = \frac{\bar{R}}{d_2}$
Step 3	$AV = \hat{\sigma}_o = \sqrt{\left[\frac{R_o}{d_2^*}\right] - \frac{o}{nop} \hat{\sigma}_{pe}^2}$
Step 4	$GRR = \hat{\sigma}_e = \sqrt{EV^2 + AV^2}$
Step 5	$PV = \hat{\sigma}_p = \frac{R_p}{d_2^*}$
Step 6	$TV = \hat{\sigma}_s = \sqrt{EV^2 + AV^2 + PV^2}$
Step 7	$\%EV = 100[EV / TV]$
Step 8	$\%AV = 100[AV / TV]$
Step 9	$\%GRR = 100[GRR / TV]$
Step 10	$\%PV = 100[PV / TV]$
Step 11	$ndc = 1.41 \frac{PV}{GRR}$

Table 2.1 Steps followed in AIAG method

Where,

URL- upper range limit

d_2, D_4 - values from Factors for Constructing Variables Control Charts (Appendix A)

d_2^* are the values associated with the distribution of the Average Range (Appendix B)

o - number of operators

n - number of trials

p - number of parts

R_o - Range of operator averages

R_p - Range of part averages

ndc - number of distinct categories

$\hat{\sigma}_{pe}$, $\hat{\sigma}_o$, $\hat{\sigma}_p$ - estimates of equipment variation, appraiser variation and product variation respectively

$\hat{\sigma}_e$ - estimate of combined Repeatability & Repeatability

$\hat{\sigma}_x$ - estimate of total variation

2.3.2 Data Analysis Methods

The data measured or recorded for the study can be analyzed by three methods:

1. Average Range method
2. Control chart method
3. Analysis of Variance (ANOVA) method

Average Range method

The number of operators, trials and parts are selected according to the study. Each operator obtains the measurements on the parts, as per the number of trials for the study. The data is collected in a random order. The range is evaluated at each part and the variation between the measurements is estimated by calculating the average range.

Calculations for average range method are as follows:

$$\text{Range, } R = \text{Observation}_{\max.} - \text{Observation}_{\min.} \quad (2.14)$$

$$\text{Range Average, } \bar{R} = \sum R_i / n \quad (2.15)$$

$$\text{GRR} = \bar{R} / d_2 \quad (2.16)$$

$$\%GRR = \frac{GRR}{Tolerance} * 100 \quad (2.17)$$

As stated by AIAG, range method is a quick approximation of measurement variation and the drawback of this method is that, it does not decompose the variability into Repeatability and Reproducibility.

Control Chart (\bar{X} -R) method

The sample size selected for the study following control chart method should be greater than five. The number of operators and trials should be greater than two. The data is collected in a data sheet, under normal measurement conditions and in random order. Calculations for the averages, ranges and average ranges are performed. This method decomposes the gage variability into Repeatability and Reproducibility components. Control charts are plotted to check if process is in statistical control. On the range chart, if there are no special cases, there is an indication that all the appraisers are doing the job consistently. In case of any out of control observations, the measurements are revised and plotted again. It is an indication that the appraisers are using different methods to take the readings. On the X-bar chart, approximately half or more observations are expected to fall outside the control limits indicating that the measurement system is adequate to detect part-to-part variation and also can be used in analyzing and controlling the process. Depending on these results R&R is concluded for further action. Figures 2.4 and 2.5 depict data collection and report sheets of GRR Study that is standardized by the AIAG.

MEASUREMENT SYSTEMS ANALYSIS																																																																																																																																											
REPEATABILITY & REPRODUCIBILITY								DATE _____																																																																																																																																			
GAGE NAME	_____	CHARACTERISTIC	_____																																																																																																																																								
GAGE TYPE	_____	SPECIFICATION	_____																																																																																																																																								
GAGE NUMBER	_____	TEST NUMBER	_____																																																																																																																																								
APPRaiser A NAME	_____	APPRaiser B NAME	_____																																																																																																																																								
SAMPLE SIZE	_____	APPRaisERS	_____	APPRaiser C NAME	_____																																																																																																																																						
		TRIALS	_____																																																																																																																																								
Appraiser/ Trial #									AVG																																																																																																																																		
A																																																																																																																																											
1																																																																																																																																											
2																																																																																																																																											
AVG'S									Xa																																																																																																																																		
Range									Ra																																																																																																																																		
B																																																																																																																																											
1																																																																																																																																											
2																																																																																																																																											
AVG'S																																																																																																																																											
Range									Rb																																																																																																																																		
C																																																																																																																																											
1																																																																																																																																											
2																																																																																																																																											
AVG'S									Xc																																																																																																																																		
Range									Rc																																																																																																																																		
Part									X																																																																																																																																		
Average									Rp																																																																																																																																		
<table border="0"> <tr> <td colspan="2">RANGE VARIATION</td> <td></td> <td></td> <td></td> <td></td> <td></td> <td></td> <td></td> <td></td> </tr> <tr> <td>Ra</td><td></td> <td># Trials</td><td>D₂</td> <td colspan="2">Rdoublebar x (D₂) = UCL_n</td> <td colspan="4"></td> </tr> <tr> <td>Rb</td><td></td> <td>2</td><td>3.267</td> <td colspan="2">=</td> <td colspan="4"></td> </tr> <tr> <td>Rc</td><td></td> <td>3</td><td>2.575</td> <td colspan="2">=</td> <td colspan="4">Note: LCL is zero with < 8 trials</td> </tr> <tr> <td>SUM</td><td></td> <td></td><td></td> <td></td><td></td> <td></td><td></td> <td></td><td></td> </tr> <tr> <td>Rdoublebar</td><td></td> <td># Trials</td><td>A₂</td> <td colspan="2">Xbar + (Rbar x A₂) = UCL_x</td> <td colspan="4"></td> </tr> <tr> <td></td><td></td> <td>2</td><td>1.880</td> <td colspan="2">=</td> <td colspan="4"></td> </tr> <tr> <td></td><td></td> <td>3</td><td>1.023</td> <td colspan="2">=</td> <td colspan="4"></td> </tr> <tr> <td></td><td></td> <td></td><td></td> <td colspan="2">Xbar - (Rbar x A₂) = LCL_x</td> <td colspan="4"></td> </tr> <tr> <td></td><td></td> <td></td><td></td> <td colspan="2">=</td> <td colspan="4"></td> </tr> <tr> <td>Max. X</td><td></td> <td colspan="2"></td> <td colspan="2">Tolerance =</td> <td></td> <td># Trials - n =</td> <td colspan="2"></td> </tr> <tr> <td>Min. X</td><td></td> <td colspan="2"></td> <td colspan="2"></td> <td></td> <td># Appr. - r =</td> <td colspan="2"></td> </tr> <tr> <td>X Diff</td><td></td> <td colspan="2"></td> <td colspan="2"></td> <td></td> <td></td> <td colspan="2"></td> </tr> </table>										RANGE VARIATION										Ra		# Trials	D ₂	Rdoublebar x (D ₂) = UCL _n						Rb		2	3.267	=						Rc		3	2.575	=		Note: LCL is zero with < 8 trials				SUM										Rdoublebar		# Trials	A ₂	Xbar + (Rbar x A ₂) = UCL _x								2	1.880	=								3	1.023	=										Xbar - (Rbar x A ₂) = LCL _x										=						Max. X				Tolerance =			# Trials - n =			Min. X							# Appr. - r =			X Diff									
RANGE VARIATION																																																																																																																																											
Ra		# Trials	D ₂	Rdoublebar x (D ₂) = UCL _n																																																																																																																																							
Rb		2	3.267	=																																																																																																																																							
Rc		3	2.575	=		Note: LCL is zero with < 8 trials																																																																																																																																					
SUM																																																																																																																																											
Rdoublebar		# Trials	A ₂	Xbar + (Rbar x A ₂) = UCL _x																																																																																																																																							
		2	1.880	=																																																																																																																																							
		3	1.023	=																																																																																																																																							
				Xbar - (Rbar x A ₂) = LCL _x																																																																																																																																							
				=																																																																																																																																							
Max. X				Tolerance =			# Trials - n =																																																																																																																																				
Min. X							# Appr. - r =																																																																																																																																				
X Diff																																																																																																																																											

Figure 2.4. GRR Data Collection Sheet

GAGE TYPE	_____	DATE	_____
TEST NUMBER	_____	APPRaiser A NAME	_____
		APPRaiser B NAME	_____
		APPRaiser C NAME	_____
REPEATABILITY - EQUIPMENT VARIATION (EV) EV = R1 X K1 K1 (trials)= EV = _____		% EV = 100 (EV/TV) % EV = _____ Percent of Tolerance: 100(EV/Tol) = _____	
REPRODUCIBILITY - APPRAISER VARIATION (AV) AV = SQ. ROOT ((X DIFF X K2)/SQUARED - (EV SQUARED/NR)) AV = _____ K2 (appraisers)=		% AV = 100(AV/TV) % AV = _____ Percent of Tolerance: 100(AV/Tol) = _____	
REPEATABILITY & REPRODUCIBILITY (R&R) R&R = SQ. ROOT (EV SQUARED + AV SQUARED) R&R = _____		% R&R = 100(R&R/TV) % R&R = _____ Percent of Tolerance: 100(R&R/Tol) = _____	
PART VARIATION (PV) PV = Rp x K3 PARTS K3 PV = _____		% PV = 100(PV/TV) % PV = _____ Percent of Tolerance: 100(PV/Tol) = _____	
TOTAL VARIATION (TV) TV = SQ. ROOT(R&R SQUARED + PV SQUARED) TV = _____			

Figure 2.5. GRR Report

Analysis of Variance Method

The ANOVA method tests the hypotheses of mean biases of the experiment and also provides estimates of the variance components attributed to gage and operator. The assumptions of ANOVA method involved in this analysis as stated by Tsai (1988) are as follows:

1. The operator, part interaction and gage (error) effects are additive
2. The operator, part and gage effects are normally distributed with zero mean and variances
3. The gage errors must be independent of the operator, part and interaction effects of each other

The total variation is partitioned into operator, part, interaction between operator and part as shown in ANOVA table of Figure 2.6, from a factorial design. In a two-way ANOVA with interaction, three hypotheses are tested which are:

1. H_0 : All parts are similar Vs. H_1 : All parts are not similar
2. H_0 : All operators are equally good Vs. H_1 : All operators are not equally good
3. H_0 : Interactions between parts and operators are negligible Vs. H_1 : Interactions between parts and operators are not negligible

The data collected for ANOVA at random and graphical analysis is performed on the data. Graphical analyses like normal probability plot, half-normal plot, residual plots and interaction plots are generated in order to provide further insight on the data collected. The numerical calculations can be done manually, but software is used due to complexity.

Source of variability	Sum of square	Degrees of freedom	Mean of square	Expected mean square
Parts	SS_P	$n_p = n - 1$	MS_P	$E(MS_P) = \sigma_R^2 + k\sigma_{PO}^2 + pk\sigma_P^2$
Inspector	SS_O	$n_o = p - 1$	MS_O	$E(MS_O) = \sigma_R^2 + k\sigma_{PO}^2 + nk\sigma_O^2$
Parts*inspector	SS_{PO}	$n_{po} = (n - 1)(p - 1)$	MS_{PO}	$E(MS_{PO}) = \sigma_R^2 + k\sigma_{PO}^2$
Error	SS_R	$n_R = np(k - 1)$	MS_R	$E(MS_R) = \sigma_R^2$
Total	SS_T	$npk - 1$		

Figure 2.6. ANOVA Table (Source: Pan,2004)

Based on the results obtained in the ANOVA table, decisions are made on the significance of the sources of variability. The ANOVA method is better over the other methods as the experiment can be designed for any kind of gage setting and this method's estimates of variances are accurate and gives information about part and operator interaction as stated by Tsai, 1998.

2.3.3 Interpretation of GRR Study

From the results obtained for the study, the Repeatability and Reproducibility are compared in order to take necessary actions for the improvement of the measurement system.

There are two cases:

Case 1: Repeatability > Reproducibility

1. Gage needs maintenance, redesign, repairs or replacement
2. Improve clamping or location of the gage
3. Presence of excessive within-part variation

Case 2: Reproducibility > Repeatability

1. Appraisers or operators need better training
2. Improper calibration of the gage

2.3.4 Decision Making Criteria

In order to make a decision about the measurement system for the GRR study, AIAG has set up a criteria index for the practitioners shown in Table 2.2.

% R&R	Criteria
Error<10%	MS is acceptable
10%-error-30%	MS may be acceptable
Error>30%	MS needs improvement

Table 2.2. Gage R&R Criteria

The final acceptance of the measurement system should not be confined to a single set of indices. The long-term performance of the measurement system should be under continuous review using graphical analyses.

2.4 Wheeler's Method (Wheeler, 2009):

Wheeler (2009) proposed a methodology of 14 steps to perform a GRR Study which is shown in Table 2.3.

STEPS	FORMULAE
Step 1	$URL = D_4 \bar{R}$
Step 2	$\sigma_{pc}^2 = \left[\frac{\bar{R}}{d_2} \right]^2$
Step 3	$\sigma_o^2 = \left\{ \left[\frac{R_p}{d_2} \right]^2 - \frac{\sigma_{pc}^2}{nop} \right\}$
Step 4	$\sigma_e^2 = \sigma_{pc}^2 + \sigma_o^2$
Step 5	$\sigma_p^2 = \left[\frac{R_p}{d_2} \right]^2$
Step 6	$\sigma_x^2 = \sigma_p^2 + \sigma_e^2$
Step 7	Repeatability Proportion = $\frac{\sigma_{pc}^2}{\sigma_x^2}$
Step 8	Reproducibility Proportion = $\frac{\sigma_o^2}{\sigma_x^2}$
Step 9	Combined R& R proportion = $\frac{\sigma_e^2}{\sigma_x^2}$
Step 10	Proportion due to product variation = $\frac{\sigma_p^2}{\sigma_x^2}$
Step 11	The capabilities are calculated w.r.t step 10
Step 12	Probable Error (PE) = $0.675 \sqrt{\sigma_{pc}^2}$
Step 13	Bounds of measurement increment are computed- 0.2 PE and 2 PE
Step 14	Manufacturing specifications are computed by tightening watershed specifications by 2 Probable Errors on each end

Table 2.3 Steps in Wheeler's method

Interpretation of the Results

Wheeler presented four classes of process monitors to interpret the proportions. This was designed as shown in Figure 2.7, based on the ratio of combined R&R and total variation, which is

$$\sigma_e/\sigma_x = \sqrt{1-\rho} \quad (2.18)$$

Where,

ρ - Intraclass correlation coefficient

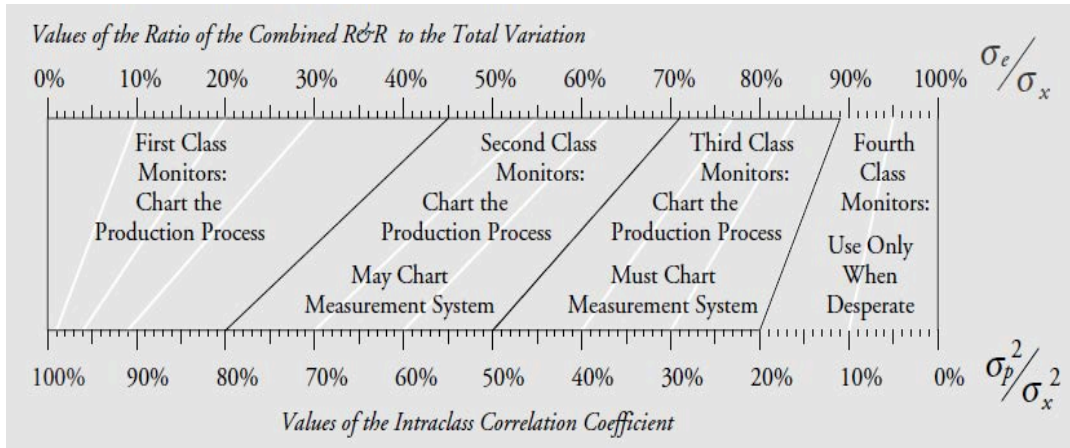

Figure 2.7 Four classes of process monitors

After the class of process monitor is categorized for the gage, the results are further interpreted respective to each class as shown in Figure 2.8.

Intraclass Correlation	Attenuation of Process Signals	Chance of Detecting a 3 Std. Error Shift	Ability to Track Process Improvements
1.00			
First Class Monitors	Less than 10 Percent	More than 99% with Rule One	Up to
0.80			C_{p80}
Second Class Monitors	From 10 % to 30 %	More than 88% with Rule One	Up to
0.50			C_{p50}
Third Class Monitors	From 30% to 55%	More than 91% w/ Rules 1, 2, 3, 4	Up to
0.20			C_{p20}
Fourth Class Monitors	More than 55 Percent	Rapidly Vanishes	Unable to Track
0.00			

$$C_{p80} = \frac{USL - LSL}{6 \sigma_{pe}} \sqrt{1-.80} \quad C_{p50} = \frac{USL - LSL}{6 \sigma_{pe}} \sqrt{1-.50} \quad C_{p20} = \frac{USL - LSL}{6 \sigma_{pe}} \sqrt{1-.20}$$

Figure 2.8 Characterization of measurement system based on class monitor

2.5 VIBRATIONS

A vibration is a periodic oscillation about an equilibrium or fixed point (Taylor & Francis, 1993). The vibration repeats itself for a certain time interval called time period of vibration, T and its inverse $1/T$ is the frequency, f , expressed in units of cycles per second (cps) or Hertz (Hz). In order to express periodic motion, harmonic function is the simplest type of periodic function. This is represented by a mass suspended from a spring in Figure 2.9. The mass when displaced from its rest position tends to oscillate up and down. The motion is expressed by the equation given by Thomson, 1993 as:

$$x = A \sin (\omega t) \quad (2.19)$$

where,

x - vibration displacement

A - amplitude

m – mass

k – spring constant

ω = circular frequency (radians per second)

t = time (seconds)

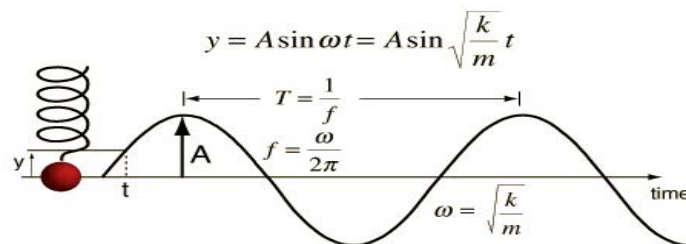

Figure 2.9 Small oscillations of a spring and mass set up (Source: www.hyperphysics.com)

2.5.1 Vibrations Analysis

The process of vibration analysis is performed by gathering data from the required structures, but there are several sources of vibrations (Goldman, 1999). Each source of vibration results in the generation of its own curve, which are added and displayed as a cumulative profile. These profiles can be represented in time domain and frequency domain. Vibration displacement, velocity and acceleration can be specified in time and frequency domain.

Time Domain

The vibration data, plotted on amplitude vs. time is represented as time domain. Amick (1999) defined time domain data as “equivalent representations of physical motion, wherein motion is quantified as a set of amplitudes as a function of time”. Either instantaneous amplitude or average such as root mean square (rms) is used in time domain. Generally, actual time-domain data are referred to as time traces or time plots (Figure 2.10a) where as theoretical vibration data are referred as waveforms (Figure 2.10b).

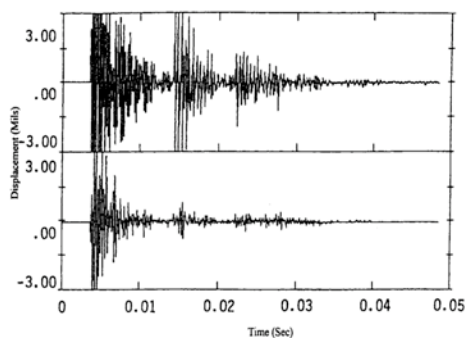

Figure 2.10a. Actual time-domain signature waveform (Source: Harris, 1996)

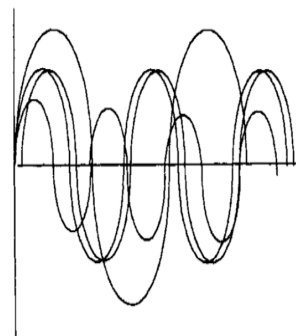

Figure 2.10b. Theoretical time domain (Source: Harris, 1996)

Frequency Domain

The frequency domain analysis is obtained by converting time domain data using a mathematical method called Fast Fourier Transform (FFT). It is a conversion to spectra, which are defined by their frequency bandwidth and in regard to vibration. They can be stated as narrowband, one-third-octave bandwidth and spectral density. Figure 2.10c illustrates a typical frequency-domain data representation.

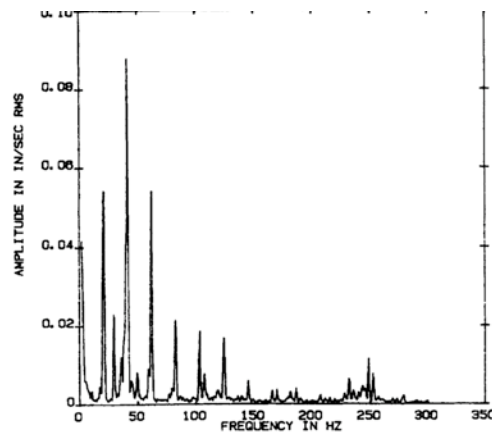

Figure 2.10c. Typical frequency-domain signature

(Source: Harris, 1996)

Both time-domain and frequency-domain data can be obtained in steady state and dynamic state for analysis under single-channel or multiple-channel methods.

2.5.2 Reasons for Vibrations Testing

Vibration testing is performed for a number of reasons (McConnell, 1995) which are as follows engineering development testing, qualification testing, reliability qualification testing, production screening tests, machinery condition monitoring.

In real time, any mechanical structure is subjected to vibrations. These vibrations are good in some scenarios where as in most of the cases they have to be reduced and controlled.

The unnecessary vibrations in a system tend to cause damage to the system in many ways. It might lead to the structure's wear out, reduced life, damage or failure of the structure. In order to avoid these, it is very important to understand the mechanical properties of these structures before finalizing their design specifications. Therefore, vibrations are measured in a system or structure for determining its dynamic characteristics and mechanical properties of the structure.

2.5.3 Vibration Measurement

Vibration testing requires transducers and accelerometers to measure the motion and forces. Many different methods have been developed for vibration motion testing like, full video schemes, laser beam scanning schemes, optical fibers, magnetic sensors etc. (McConnell,1995). Due to high costs and limited use these methods are not used unless demanded by certain problems.

Generally transducers and accelerometers are made up of piezoelectric sensing type. An accelerometer is a device that responds to sinusoidal and transient motions. A force transducer is a device that interacts directly with its environment. It is used under three different environments as defined by McConnell (1993). In the first environment, the transducer is attached to a rigid foundation. In other scenario, the transducer is attached to a hammer type device in order to measure impulse loads. The third environment involves placing the force transducer between a vibration exciter and structure under test.

As structures under operating conditions vary in characteristics continuously, there are various methods of vibration excitation. They are as follows (Smith,1989):

1. Electromagnetic moving coil
2. Hydraulic vibrators

3. Mechanical out-of balance systems
4. Piezoelectric devices
5. Magnetostrictive devices
6. Electromagnetic pull
7. Air excitation
8. Impact testing (vibration-impact testing)

Some vibration tests involve field measurements while the structure is in its normal operating condition, while others involve excitation of the structure by some external setting, either in field or laboratory setting. In generic vibration test equipment, motion is measured by one transducer system (accelerometer) and the input force is measured by a second transducer (force transducer). The electronic signals from these transducers are amplified electronically and analyzed. Generally, a spectrum analyzer is used for this purpose. The resulting frequency spectra are interpreted and stored using a computer.

2.5.4 Vibration-impact Testing

The most commonly used method of excitation is the use of a hammer or an impactor of different sizes. The equipment consists of an impactor, additional heads to extend the force level range and frequency level of the test structure. The figure 2.11 depicts the various hammer parts. There is a force transducer incorporated in the hammer that detects the magnitude of the force applied by the hammer, which is equal and opposite to the force experienced by the test structure. The magnitude of the impact is dependent on the mass and the velocity of hammer when it strikes the structure.

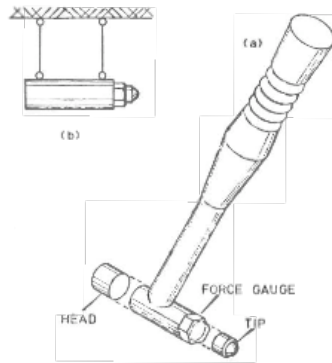

Figure 2.11. Hammer Details (Source: Ewins, 2000)

The excitation is controlled by the stiffness of the contacting surface. Hence, the stiffer the material the shorter will be the duration of the pulse and the higher will be the frequency range covered by the impact. Similarly, the lighter the impactor mass, the higher the effective frequency range (Amick, 1999). On the contrary, the difficulty in the use of this mechanism is the consistency in the application of impact. Also, multiple impacts have to be avoided in order to ease the signal processing stage. These impacts, which are experienced by the force transducers of the hammers, are amplified and analyzed by a frequency analyzer. The figure 2.12 gives the description of the vibration-impact testing system.

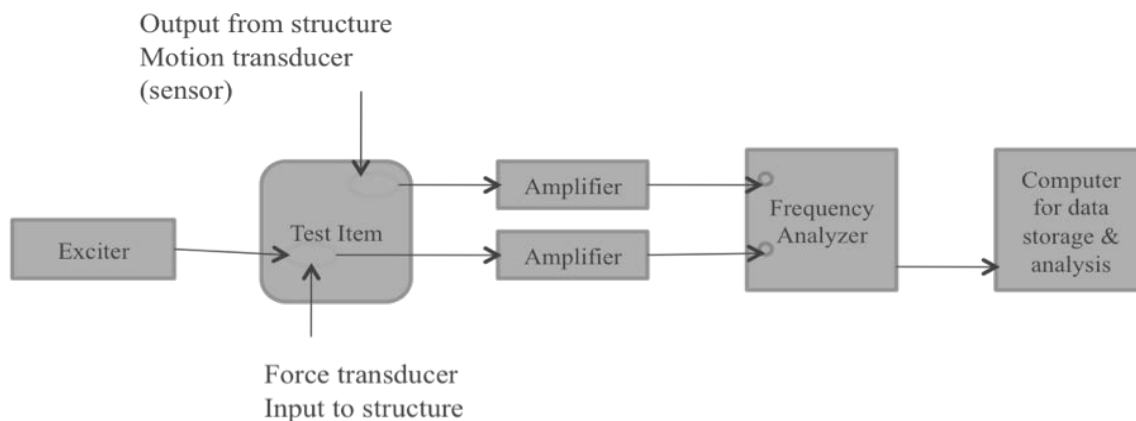

Figure 2.12 System configuration of vibration-impact testing (Source: McConnell, 1995)

2.5.5 Spectrum Analyzer

A spectrum analyzer is an electronic, vibration-monitoring device that converts a time waveform of a signal into its frequency components. The invention of spectrum analyzer can be traced back to 1965, with the development of a Fast Fourier Transform (FFT) algorithm, by Cooley and Tukey (McConnell, 1995). The spectrum analyzer is a high performance microprocessor and analog to digital (A/D) voltage converter. The FFT spectrum analyzer rapidly calculates the Fourier transform of a signal and simulates the results. The analyzer performs several basic processes. Firstly, the analyzer samples a signal over a time period T using an A/D converter that samples at a constant rate (Moblely, 1999). Secondly, standard periodic Fourier series frequency components are calculated based on the assumption that only multiples of fundamental frequencies are present in the signal. The analyzer manipulates these frequency components in order to produce various frequency analysis results. An analyzer can present frequency analysis in various required and useful formats with significant data.

2.6 Stereolithography

Stereolithography process is one of the rapid prototyping techniques, which is used for experimental model production (Dornfeld, 1995). SL process generates three-dimensional models based on CAD files by successively converting liquid photopolymer resin into several thick layers of solid polymer by exposing to ultraviolet light as shown in Figure 2.13.

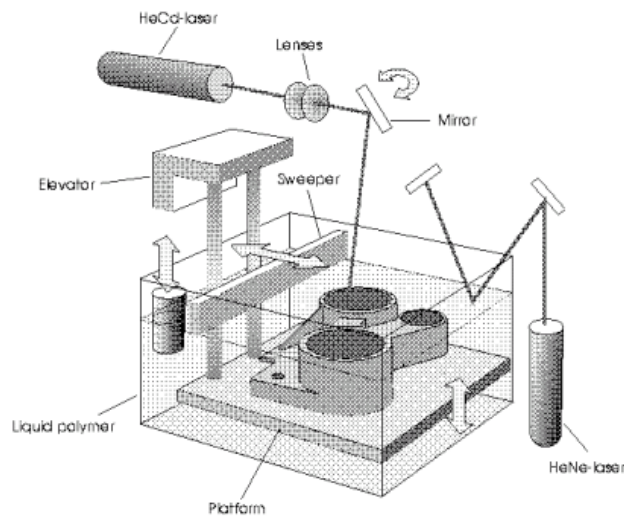

Figure 2.13 SL process (Source: Palm, 2002)

SL models are easily size-scaled and quickly produced. Also, some SL polymers have mechanical properties well suited for dynamic testing. The use of SL models makes early testing and accelerated test development work that can reduce costs and shrink the production development cycle.

There are several advantages of models generated by the SL process. They are easily producible and size scaled, process is generic, the material has properties for mechanical testing and the geometry is easily modified for attachments. Therefore, SL models are evolving for model testing or direct dynamic testing.

Mahn and Bayly (1999) stated that the SL models are used for predicting the natural frequencies of prototype parts. In their research, they presented the prediction of natural frequencies of aluminum prototypes using impact testing of SL models. Since, impact tests can be performed quickly, the SL models were convenient means of validation and iterative refinement of Finite Element Analysis (FEA) models. From the results, the SL models proved to be valuable for pre- production testing

CHAPTER 3

CASE STUDY

This chapter represents a case study involving vibration impact tester. The study is aimed at evaluating the gage Repeatability and Reproducibility of the measurement system. Two methods were used for performing the Gage R & R study. The same set of data was analyzed for quantification of sources of variation in the measurement system by AIAG method and Wheeler's method. The results from these methods were compared and the selection of appropriate method is discussed.

3.1 Spectrum Analyzer- Quattro and Specifications

The gage consists of Quattro (hardware), which is interfaced to the computer with the help of Signal Calc software. Figure 3.1 depicts the model of the gage that was used for vibration-impact testing. The Quattro is 4 inputs and 2 outputs, which makes it appropriate for modal testing. The hardware specifications are shown in table 3.1.



Figure 3.1 Quattro- Dynamic Signal Analyzer used for this study (Source: dataphysics.com)

Quattro- Hardware Specifications

The tables 3.1 detail the input specifications and the chassis configuration of the spectrum analyzer- Quattro. Based on the type of test, the setting of the gage is decided by the tester.

<p>INPUT</p> <p>Amplitude Accuracy: +/-0.020dB at 1kHz for 15degC<T<40degC</p> <p>Phase Accuracy: 0.05deg to 0.5deg for DC to 40kHz</p> <p>Time Accuracy: 25ppm</p> <p>Frequency Accuracy: 25ppm</p> <p>Max Frequency: 200kHz</p> <p>CHASSIS DETAILS</p> <p>Dimensions: 5.6"x 4.0" x 0.9"</p> <p>Operating Temp.: 0 to 55°C</p>

Table 3.1 Quattro Specifications

Research Methodology

The flow chart in figure 3.2 describes the various stages in which the research was carried out.

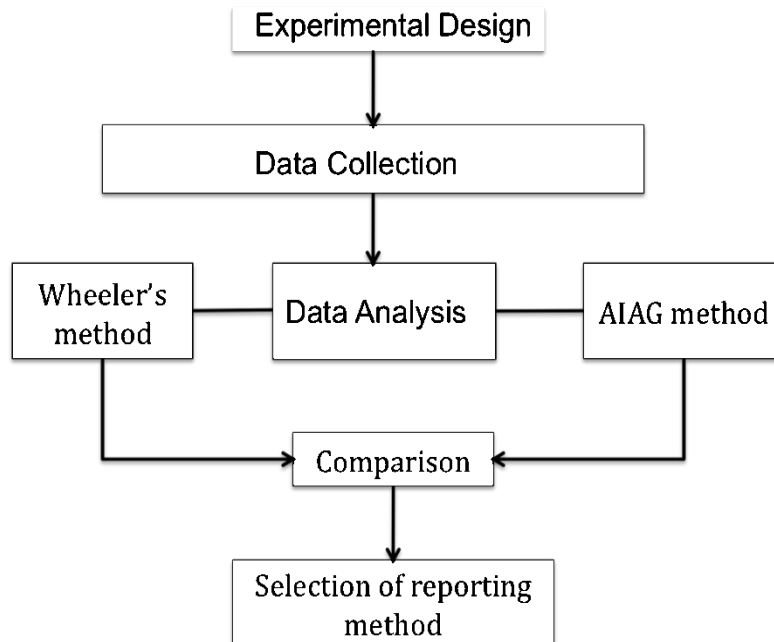

Figure 3.2 Flow Chart showing the research methodology

3.2 Experimental Design:

For this study, SL parts were selected for the measurement of natural frequency as the characteristic of interest. Nine parts were chosen at random, three of each belonging to three different orientations (X, Y and Z directions) of built. Two trained operators, A and B, collected the data by performing three trials on each part. Both the operators following the same method, using the same equipment, conducted a randomized test.

3.3 Data Collection:

Vibration-impact testing was conducted on the SL parts. The SL parts are hung freely from a vice using elastomeric bands attached to them. The suspended part is excited, by

striking with the hammer in order to obtain a frequency response function. The frequency response function is displayed in Figure 3.3 in the form of a rectangular plot, which is frequency versus real part and imaginary part. From these plots the readings are noted. This modal testing identifies the frequency, damping, stiffness and mode shape and helps in the further analysis. For this research only the natural frequency was considered as the characteristic to be measured. Both the operators took readings on all the other parts with repetition.

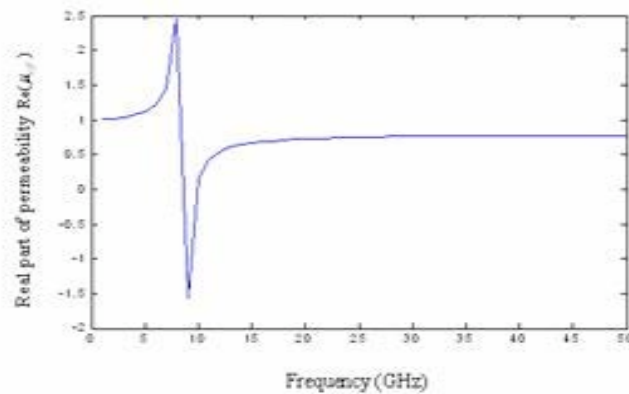

Figure 3.3 Output display of frequency plot

From the experimental set up, the readings obtained consisted of 2-peak frequencies, natural frequency and their corresponding magnitude values for each part. Only the natural frequency was considered. The measurements were taken in random order in Table 3.2.

Natural Frequency (Hz) Readings						
Operator-A Readings			Operator-B Readings			
Trial	Z-orientation	Y-orientation	X-orientation	Z-orientation	Y-orientation	X-orientation
	Z1	Y1	X1	Z1	Y1	X1
1	1597	1616	1603	1593	1603	1606
2	1593	1619	1603	1597	1603	1606
3	1593	1619	1603	1597	1603	1606
	Z2	Y2	X2	Z2	Y2	X2
1	1593	1616	1606	1597	1603	1606
2	1593	1619	1606	1593	1603	1606
3	1597	1616	1606	1597	1603	1609
	Z3	Y3	X3	Z3	Y3	X3
1	1597	1616	1606	1591	1628	1609
2	1597	1616	1606	1591	1628	1609
3	1597	1619	1606	1591	1628	1609

Table 3.2 Data collected by operators A and B

3.4 Data Analysis

The data collected was analyzed by calculating the averages, ranges, average ranges and part averages as shown in Table 3.4. X bar and R chart was plotted for further analysis.

Operator A									
Part	1	2	3	4	5	6	7	8	9
Trial 1	1597	1593	1597	1616	1616	1616	1603	1606	1606
Trial 2	1593	1593	1597	1619	1619	1616	1603	1606	1606
Trial 3	1593	1597	1597	1619	1616	1619	1603	1606	1606
Averages	1594.33333	1594.33333	1597	1618	1617	1617	1603	1606	1606
Ranges	4	4	0	3	3	3	0	0	0
Operator B									
Part	1	2	3	4	5	6	7	8	9
Trial 1	1593	1597	1591	1603	1603	1628	1606	1606	1609
Trial 2	1597	1593	1591	1603	1603	1628	1606	1606	1609
Trial 3	1597	1597	1591	1603	1603	1628	1606	1609	1609
Averages	1595.66667	1595.66667	1591	1603	1603	1628	1606	1607	1609
Ranges	4	4	0	0	0	0	0	3	0
Part Avgs.	1595	1595	1594	1610.5	1610	1622.5	1604.5	1606.5	1607.5

Table 3.3 Calculated Averages and Ranges for the data

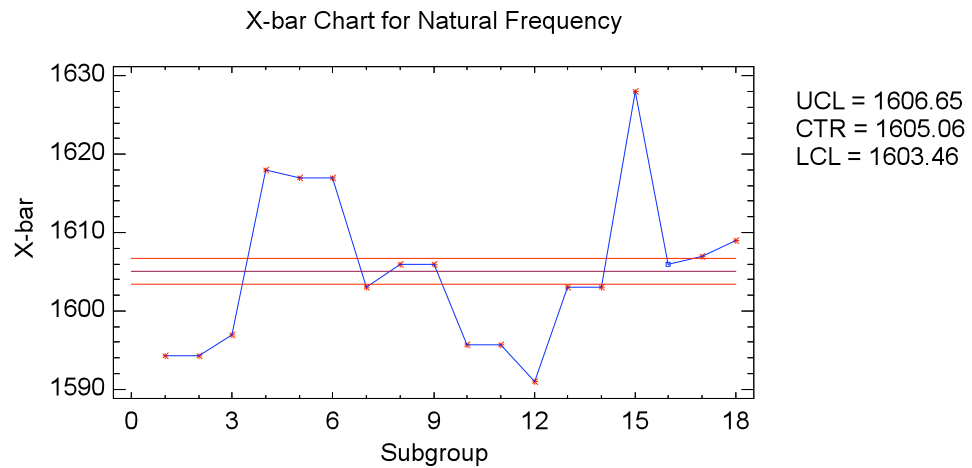

Figure 3.4 X-bar chart plotted for Natural Frequency

From the X bar chart in Figure 3.4, it is evident that most of the average points lie outside the control limits. This indicates that the measurement system is adequate in detecting part-to-part variation.

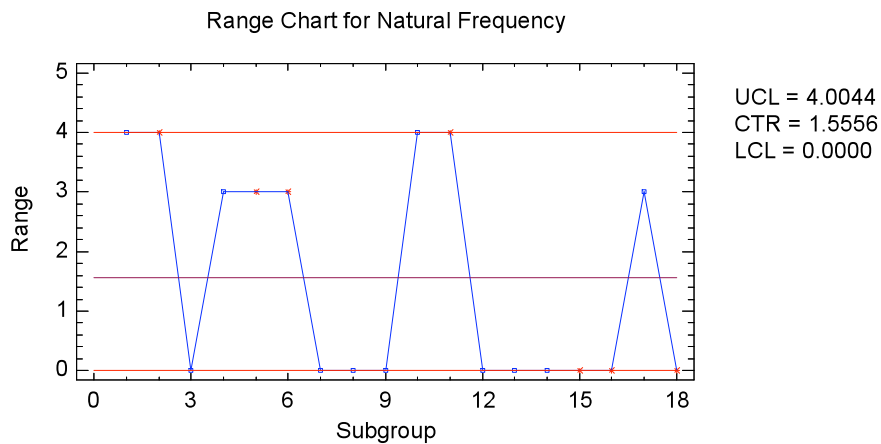

Figure 3.5 Range chart plotted for Natural Frequency

From the Range chart in Figure 3.5, all the ranges are within the control limits. This indicates that the operators followed the same method and were consistent in taking the readings

3.5 Results

The results were obtained by following AIAG method and Wheeler's method. As mentioned in chapter 2, the steps were followed to calculate the estimates of variation. The obtained estimates from AIAG method are listed in Table 3.5 and that from Wheeler's method are listed in Table 3.6.

Source	Estimates	% of Total Variation	Decision
Repeatability	0.9191	8.17	Acceptable
Reproducibility	0.9169	8.15	Acceptable
Combined R&R	1.2982	11.54	Marginal
Product variation	11.1759	99.33	No criteria given
Total Variation	11.2511		

Table 3.4 Results from AIAG method

The estimates are in terms of standard deviation, and they are calculated as percentages of total variation. These proportions are compared to the decision criteria mentioned by AIAG standard in Table 2.1. The Repeatability is 8.17%, which is below 10% according to the standard and hence is an acceptable limit for this gage. The measurement system's variability, Repeatability is satisfactory and is adequate in this case.

The Reproducibility is 8.15% and below the acceptable limit of 10%. Therefore, this variability for the measurement system is satisfactory and adequate. The variability, Combined R&R is 11.54%, which is over 10% and in the range of marginal acceptance. It is accepted depending on the gage settings, measurement method followed by the operators, calibration of the gage etc.

The Product variation is 99.33%, which is the major contributor out of the total variation. This is an indication that, the parts have variation among them that arised during their manufacture. Since, the parts chosen for this study are manufactured in three different orientations, this could be one of the major factors for such high Product variation.

The main observation that is made in this analysis is that the Combined R&R and Product variation do not add up to be 100%.

The results obtained using Wheeler’s methods are shown in Table 3.5. In this method the estimates are calculated using variance.

Source	Varaince Estimates	Proportions
Repeatability	0.8447	0.667
Reproducibility	0.8456	0.668
Combined R&R	1.6903	1.34
Product variation	124.9008	98.66
Total Variation	126.5911	

Table 3.5 Results from Wheeler’s method

Based on the guidelines of four classes of process monitors presented in Wheeler’s method, the further analysis of the gage in this study are as follows:

The gage is a first class monitor for these natural frequencies. The production signals will be attenuated by $1 - \sqrt{0.9866} = 0.0067 = 0.67\%$. The chance of detecting a 3 standard shift is more than 99%. The ability to track process improvement is up to $C_{p80} = 6.24$ while a first class monitor.

3.6 Comparison of Methods

The results of AIAG method and Wheeler’s method are summarized in Table 3.6. It is very clear that the sources of measurement system are inflated by AIAG method compared to Wheeler’s method. The sum of the percent consumed by each factor by AIAG does not equal to 100%, violating the basic arithmetic rule. This implies that the values do not interpret the correct information about the sources of variation. If these values are based for the adequacy of the measurement process, there is a high risk that it is misleading in the decision making. In contrast, Wheeler’s method suggested the variance of estimates and the sum of the individual proportions are equal to the total variation.

	AIAG method	Wheeler's method
Estimates (Hz)		
EV	0.9191	0.8447
AV	0.9169	0.8456
GRR	1.2982	1.6903
PV	11.1759	124.9008
TV	11.2511	126.5911
Proportions (%)		
EV	8.17	0.667
AV	8.15	0.668
GRR	11.54	1.34
PV	99.33	98.66
TV	110.87	100

Table 3.6 AIAG method Vs. Wheeler’s method

Based on the AIAG results, for this gage the metrics were within the acceptable criteria. But there is high risk that if AIAG is adopted for measurement capability studies, it could inflate the variations and misguide the practitioner towards unnecessary changes in the process. The changes made might lead to added variations in the system. The product variation according to AIAG method is 99.43% out of the total variation. Since Repeatability,

Reproducibility and Combined R&R are acceptable, the measurement system is acceptable and the major contributor is product variation.

On the other hand, Wheeler's method clearly indicated the actual proportions of variation. These variations are low when compared to the product variation and total variation. This implies that we can rely on the measurements made from this experiment. And also, that the gauge is adequate and is recommended for further use. However, the product variation is the major source of the total variability from this method. From both AIAG and Wheeler's method, product variation is high. The within part variation can be attributed to the different orientations of their built and other respective factors.

3.7 Selection of Appropriate Method

From the analysis and results, the Wheeler's method is selected over the AIAG method as it is more appropriate in its interpretation of the sources of variability. Though AIAG method underwent many modifications over the past decades, it still holds some misleading conclusions. If a practitioner relies on the AIAG method, it might lead to wrong decisions regarding the measurement system.

CHAPTER 4

SUMMARY & CONCLUSIONS

Summary

The GRR Study has been instrumental in order to characterize a measurement system. The SL parts were subjected to vibration-impact testing to measure their natural frequencies using a spectrum analyzer- Quattro. Two operators collected three measurements on each of the nine parts. The data that was collected was analyzed using two different methods, the AIAG method and Wheeler's method. The results obtained from both the methods were compared and Wheeler's method was selected and reported as appropriate.

Conclusions

The results from AIAG method and Wheeler's method were compared and it was found that the components of variation as obtained by the AIAG method do not add up to give the total variation. In this study the total variation exceeded 100%, which is a violation of basic mathematics. This is in agreement with observations made by Wheeler (2009). The decisions based on flawed results can lead to inappropriate conclusions, which in turn demand unnecessary changes in the measurement system. In contrary, the Wheeler's method obtained a set of results which were appropriate and also gave better understanding of the system in further analysis. Wheeler's method used the traditional method of relativity to calculate the variance components. By comparing the AIAG method and Wheeler's method, it can be concluded that the AIAG method resulted in estimates with high values. The combined GRR of AIAG method actually attenuates the variation signals from the measurement system rather than the production process. From this study, Wheeler's method

is strongly recommended over the AIAG method, as the measures obtained from AIAG are inflated, over estimating the measurement error components.

Apart from these methods, software is also available to perform the GRR study. But the software results cannot be trusted completely as there is always a scope of improper estimation of the sources of variation. In order to avoid any further confusion for decision making of a measurement system Wheeler's method is strongly recommended.

Future Work

The study here was confined to the characterization of the measurement system. The study can be extended to perform the measurement capability analysis. Only two factors, operators and parts are considered in this research, which can be extended to consideration of other factors such as set up, time, number of gages and temperature.

REFERENCES

REFERENCES

- Automotive Industry Action Group (AIAG). (2002). *Measurement System Analysis* (3rd edn). AIAG: Detroit, MI.
- Antony, J., Knowles, G., Roberts, P. (1998). "Gauge Capability Analysis: Classical versus Anova", *Quality Assurance*, 6, 173- 181.
- Bereret, F., Maubert, S., Sourd, P., & Puel, F. (2002). "Improving and Applying Destructive Gauge Capability", *Quality Engineering*, 14(1), 59-66.
- Barrentine, L.B. (1991). *Concepts for R&R Studies*, ASQ Quality Press, Milwaukee, WI.
- Burdick, R.K., Borror, C.M., & Montgomery, D.C. (2005). *Design and Analysis of Gauge R&R Studies: Making Decisions with Confidence Intervals in Random and Mixed ANOVA Models*, SIAM, Philadelphia, PA.
- Campbell, N. R. (1938). "Measurement and its importance for philosophy", *Proc. Aristotelian Soc. Supplement*, 17.
- Dawson, B. (2004). "Machine Vision Makes Gaging Easy", *Quality Magazine*.
- Dornfeld, W.H. (1995). "Direct dynamic testing of scaled stereolithographic models", *Sound and Vibration*, 29, pp. 12-17.
- Ewins, D.J. (2000). *Modal Testing: Theory, Practice and Application*, Research Studies Press Ltd.
- Floyd, D.A and Laurent, C.J. (1995-96). "Gauging: An Underestimated Consideration in the Application of Statistical Process Control", *Quality Engineering*, 8(1), 13-29.
- Goldma, S. (1999). *Vibration Spectrum Analysis: A Practical Approach*, Industrial Press Inc.

Harris, M.C. (1996). *Shock and Vibration Handbook*, Fourth Edition, Mc Graw-Hill, New York.

Hartog, D.J.P. (1947). *Mechanical Vibrations*, The Maple Press Co., York, PA.

Hicks, D., Vu, K. & Rao, D.M. (2003). "Study of Noise Transmission from a Nail Gun". *Proceedings of Noise-Con*, June 2003, Cleveland, OH.

Knowles, G., Antony, J. and Vickers, G. (2000). "A Practical Methodology for Analyzing and Improving the Measurement System", *Quality Assurance*, 8(2), 59-75.

Mader, P.D., Prins, J. and Lampe, E.R. (1999). "The Economic Impact of Measurement Error". *Quality Engineering*, 11(4), 563-574.

Mahn, J.P. and Bayly, P.V. (1999). "Impact Testing of Stereolithographic Models to Predict Natural Frequencies", *Journal of Sound and Vibration*. 224(3), 411-430.

Mawby, D.W. (2006). *Make your destructive, dynamic and attribute measurement system work for you*, ASQ Quality Press.

McConnell, G.K. (1995). *Vibration Testing: Theory and Practice*, John Wiley & Sons, Inc.

Montgomery, D.C. and Runger, G.C. (1993-94). "Gauge Capability and Designed Experiments. Part 1: Basic Methods", *Quality Engineering*. 6(1), 115-135.

Montgomery, D.C. and Runger, G.C. (1993-94). "Gauge Capability and Designed Experiments. Part 2: Experimental Design Models and Variance Component Estimation", *Quality Engineering*. 6(2), 289-305.

Palm, W. (2002). Retrieved on 08/15/10, from <http://www.me.psu.edu/lamancusa/rapidpro/primer/chapter2.htm>

Pan.J (2004). “Determination of the optimal allocation of parameters for gauge repeatability and reproducibility study”, *International Journal of Quality & Reliability Management.* 21(6), 672-682.

Thomson, W. (1993). *Theory of Vibration with Applications*, Fourth edition, Stanley Thomas Publishers Ltd., UK.

Tsai.P (1988-89). “Variable Gauge Repeatability and Reproducibility Study Using the Analysis of Variance Method”, *Quality Engineering*, 1(1), 107-115.

Vardeman.S.B and VanValkenburg.E.S (1999). “Two-Way Random-Effects Analyses and Gauge R&R Studies”, *Technometrics*, 41(3), 202-211.

Wang.F and Li.E.Y (2003). “Confidence intervals in repeatability and reproducibility using the bootstrap method”, *Total Quality Management*, 14(3), 341-354.

Wheeler.D (2009). “An Honest Gauge R&R Study”. Retrieved on 06/10/10

<http://www.spcpress.com/pdf/DJW189.pdf>

APPENDICES

APPENDIX A. Factors for Constructing Variables Control Charts- d_2 Values

NUMBER OF OBSERVATIONS IN SAMPLE	CHART FOR AVERAGES			CHART FOR STANDARD DEVIATIONS					
	FACTORS FOR CONTROL LIMITS			FACTORS FOR CENTRAL LINE		FACTORS FOR CONTROL LIMITS			
	A	A_1	A_2	C_2	$1/C_2$	B_1	B_2	B_3	B_4
2	2.121	3.760	1.880	.5642	1.7725	0	1.843	0	3.267
3	1.732	2.394	1.023	.7236	1.3820	0	1.858	0	2.568
4	1.501	1.880	.729	.7979	1.2533	0	1.808	0	2.266
5	1.342	1.596	.577	.8407	1.1894	0	1.756	0	2.089
6	1.225	1.410	.483	.8686	1.1512	.026	1.711	.030	1.970
7	1.134	1.277	.419	.8882	1.1259	.105	1.672	.118	1.882
8	1.061	1.175	.373	.9027	1.1078	.167	1.638	.185	1.815
9	1.000	1.094	.337	.9139	1.0942	.219	1.609	.239	1.761
10	.949	1.028	.308	.9227	1.0837	.262	1.584	.284	1.716
11	.905	.973	.285	.9300	1.0753	.299	1.561	.321	1.679
12	.866	.925	.266	.9359	1.0684	.331	1.541	.354	1.646
13	.832	.884	.249	.9410	1.0627	.359	1.523	.382	1.618
14	.802	.848	.235	.9453	1.0579	.384	1.507	.406	1.594
15	.775	.816	.223	.9490	1.0537	.406	1.492	.428	1.572
16	.750	.788	.212	.9523	1.0501	.427	1.478	.448	1.552
17	.728	.762	.203	.9551	1.0470	.445	1.465	.466	1.534
18	.707	.738	.194	.9576	1.0442	.461	1.454	.482	1.518
19	.688	.717	.187	.9599	1.0418	.477	1.443	.497	1.503
20	.671	.697	.180	.9619	1.0396	.491	1.433	.510	1.490
21	.655	.679	.173	.9638	1.0376	.504	1.424	.523	1.477
22	.640	.662	.167	.9655	1.0358	.516	1.415	.534	1.466
23	.626	.647	.162	.9670	1.0342	.527	1.407	.545	1.455
24	.612	.632	.157	.9684	1.0327	.538	1.399	.555	1.445
25	.600	.619	.153	.9696	1.0313	.548	1.392	.565	1.435
Over 25	3	3				a	b	a	b
	$\frac{3}{\sqrt{n}}$	$\frac{3}{\sqrt{n}}$							

$$a = 1 - \frac{3}{\sqrt{2n}}, b = 1 + \frac{3}{\sqrt{2n}}$$

(continued)

Continued.

NUMBER OF OBSERVATIONS IN SAMPLE <i>n</i>	CHART ROR RANGES						
	FACTORS FOR CENTRAL LINE		FACTORS FOR CONTROL LIMITS				
	<i>d</i> ₂	<i>l/d</i> ₂	<i>d</i> ₃	<i>D</i> ₁	<i>D</i> ₂	<i>D</i> ₃	<i>D</i> ₄
2	1.128	.8865	.853	0	3.686	0	3.276
3	1.693	.5907	.888	0	4.358	0	2.575
4	2.059	.4857	.880	0	4.698	0	2.282
5	2.326	.4299	.864	0	4.918	0	2.115
6	2.534	.3946	.848	0	5.078	0	2.004
7	2.704	.3698	.833	.205	5.203	.076	1.924
8	2.847	.3512	.820	.387	5.307	.136	1.864
9	2.970	.3367	.808	.546	5.394	.184	1.816
10	3.078	.3249	.797	.687	5.469	.223	1.777
11	3.173	.3152	.787	.812	5.534	.256	1.744
12	3.258	.3069	.778	.924	5.592	.284	1.719
13	3.336	.2998	.770	1.026	5.646	.308	1.692
14	3.407	.2935	.762	1.121	5.693	.329	1.671
15	3.472	.2880	.755	1.207	5.737	.348	1.652
16	3.532	.2831	.749	1.285	5.779	.364	1.636
17	3.588	.2787	.743	1.359	5.817	.379	1.621
18	3.640	.2747	.738	1.426	5.854	.392	1.608
19	3.689	.2711	.733	1.490	5.888	.404	1.596
20	3.735	.2677	.729	1.548	5.922	.414	1.586
21	3.778	.2647	.724	1.606	5.950	.425	1.575
22	3.819	.2618	.720	1.659	5.979	.434	1.566
23	3.858	.2592	.716	1.710	6.006	.443	1.557
24	3.895	.2567	.712	1.759	6.031	.452	1.548
25	3.931	.2544	.709	1.804	6.058	.459	1.541

APPENDIX B. Duncan's table for d_2^* Values

# of subgroups (g)	Subgroup size (n)																			
	2	3	4	5	6	7	8	9	10	11	12	13	14	15	16	17	18	19	20	
1	1.414	1.912	2.239	2.481	2.673	2.83	2.963	3.078	3.179	3.269	3.35	3.424	3.491	3.553	3.612	3.664	3.741	3.761	3.805	
2	1.279	1.805	2.151	2.405	2.604	2.768	2.906	3.025	3.129	3.221	3.305	3.38	3.449	3.513	3.571	3.63	3.677	3.725	3.77	
3	1.231	1.769	2.12	2.379	2.581	2.747	2.886	3.006	3.112	3.205	3.289	3.366	3.435	3.499	3.558	3.613	3.665	3.713	3.759	
4	1.206	1.75	2.105	2.366	2.57	2.736	2.877	2.997	3.103	3.197	3.282	3.358	3.428	3.492	3.552	3.607	3.659	3.707	3.753	
5	1.191	1.739	2.096	2.358	2.563	2.73	2.871	2.992	3.098	3.192	3.277	3.354	3.424	3.488	3.545	3.603	3.655	3.704	3.749	
6	1.181	1.731	2.09	2.353	2.558	2.726	2.867	2.988	3.095	3.189	3.274	3.351	3.421	3.486	3.545	3.6	3.652	3.701	3.747	
7	1.173	1.726	2.085	2.349	2.555	2.723	2.864	2.986	3.092	3.187	3.272	3.349	3.419	3.484	3.543	3.6	3.651	3.699	3.745	
8	1.168	1.721	2.082	2.346	2.552	2.72	2.862	2.984	3.09	3.185	3.27	3.347	3.417	3.482	3.542	3.6	3.65	3.698	3.744	
9	1.164	1.718	2.08	2.344	2.55	2.719	2.86	2.982	3.089	3.184	3.269	3.346	3.416	3.481	3.541	3.6	3.65	3.697	3.744	
10	1.16	1.716	2.077	2.342	2.549	2.717	2.859	2.981	3.088	3.183	3.268	3.345	3.415	3.48	3.54	3.6	3.65	3.696	3.742	
11	1.157	1.714	2.076	2.34	2.547	2.716	2.858	2.98	3.087	3.182	3.267	3.344	3.415	3.479	3.54	3.6	3.65	3.696	3.741	
12	1.155	1.712	2.074	2.343	2.546	2.715	2.857	2.979	3.086	3.181	3.266	3.343	3.414	3.479	3.54	3.6	3.646	3.695	3.741	
13	1.153	1.71	2.073	2.338	2.545	2.714	2.856	2.978	3.085	3.18	3.266	3.343	3.413	3.478	3.54	3.6	3.646	3.695	3.74	
14	1.151	1.709	2.072	2.337	2.545	2.714	2.856	2.978	3.085	3.18	3.265	3.342	3.413	3.478	3.54	3.593	3.645	3.694	3.74	
15	1.15	1.708	2.071	2.337	2.544	2.713	2.855	2.977	3.084	3.179	3.265	3.342	3.412	3.477	3.54	3.593	3.645	3.694	3.74	
16	1.148	1.707	2.07	2.336	2.543	2.712	2.855	2.978	3.084	3.179	3.264	3.342	3.412	3.477	3.54	3.593	3.644	3.694	3.74	
17	1.147	1.706	2.07	2.335	2.543	2.711	2.854	2.977	3.084	3.179	3.264	3.341	3.412	3.477	3.54	3.592	3.644	3.693	3.74	
18	1.146	1.705	2.069	2.334	2.542	2.711	2.854	2.976	3.083	3.178	3.263	3.341	3.411	3.477	3.54	3.592	3.644	3.693	3.74	
19	1.145	1.705	2.069	2.334	2.542	2.711	2.853	2.976	3.083	3.178	3.263	3.341	3.411	3.477	3.54	3.591	3.644	3.693	3.74	
20	1.144	1.704	2.068	2.333	2.541	2.712	2.853	2.976	3.083	3.178	3.263	3.34	3.411	3.476	3.54	3.592	3.644	3.693	3.74	